

**2015 Chevy Colorado**

**2015 GMC Canyon**

**Document ID: 4167626**

**Kent material list:**

**Ure-Foam, P10601 (replaces 3M 08463)**

Document ID: 4167626

## #15069: Service Update for Inventory and Customer Vehicles - C-Pillar Baffle Noise - Expires with Base Warranty - (Apr 21, 2015)

**Subject: Service Update for Inventory and Customer Vehicles – C-Pillar Baffle Noise – Expires with Base Warranty**

**Models: 2015 Chevrolet Colorado  
2015 GMC Canyon**



This service update includes vehicles in dealer inventory and customer vehicles that return to the dealership for any reason. This bulletin will expire at the end of the involved vehicle's New Vehicle Limited Warranty period.

### Purpose

This bulletin provides a service procedure to inspect and ensure that the c-pillar baffles are present on **certain** 2015 model year Chevrolet Colorado and GMC Canyon vehicles. On these vehicles, there is the potential that the c-pillar baffles were not correctly installed and may be missing. If a baffle is missing, the vehicle is not properly sealed, which could permit additional sound, air, water, and other external materials to enter into the passenger compartment. This will also impact the HVAC systems ability to sustain the desired temperature within the passenger compartment.

**This service procedure should be completed as soon as possible on involved vehicles currently in dealer inventory and customer vehicles that return to the dealer for any type of service during the New Vehicle Limited Warranty coverage period.**

### Vehicles Involved

All involved vehicles are identified by VIN in the Global Warranty Management System – Investigate Vehicle History Application. Dealership technicians should always check this site to confirm vehicle involvement prior to beginning any required inspections and/or repairs. It is important to routinely use this tool to verify eligibility because not all similar vehicles may be involved regardless of description or option content.

Additionally, a list of involved vehicles currently in dealer inventory is available on the "Service Update Bulletin Information" link under the "Service" tab in GM GlobalConnect used to release this bulletin. Customer vehicles that return for service, for any reason, and are still covered under the vehicle's base warranty should also be checked for vehicle eligibility.

### Parts Information

Parts required to complete this service update are to be obtained from General Motors Customer Care and Aftersales (GMCCA). Please refer to your "involved vehicles listing" before ordering parts. Normal orders should be placed on a DRO = Daily Replenishment Order. In an emergency situation, parts should be ordered on a CSO = Customer Special Order.

Part Number	Description	Quantity/Vehicle
11611776	BOLT/SCREW	2 or 4 (If Req'd)
08463 (Obtain from 3M™*)	3M™ FLEXIBLE FOAM © 2015 General Motors. All rights reserved.	1 (If Req'd)

	(Submit in Net Item)
--	----------------------

\* Contact your local 3M™ representative or the 3M™ Automotive Aftermarket Product Helpline at 1-877-MMM-CARS (1-877-666-2277). **Do not order from GMCCA.**

### Service Procedure

#### **Baffle Inspection**



**Note:** Inspect for the existence of a baffle, positioned between the inner and outer C-pillar sheet metal during the body shop production process. Though not visible from the exterior, its left side location is shown circled above.

1. Raise and support the vehicle. Refer to *Lifting and Jacking the Vehicle* in SI.

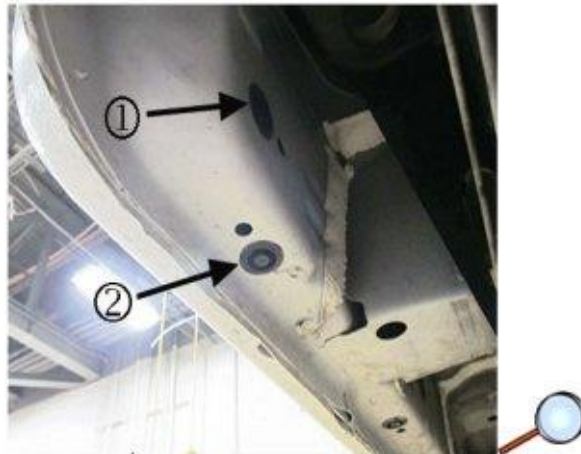

2. Locate the body plug (2) in the rear, C-pillar area of the rocker panel. There is one plug located on each side of the truck.
3. Remove that body plug and a second plug (1) in the vertical portion of the rocker, just above the first plug.

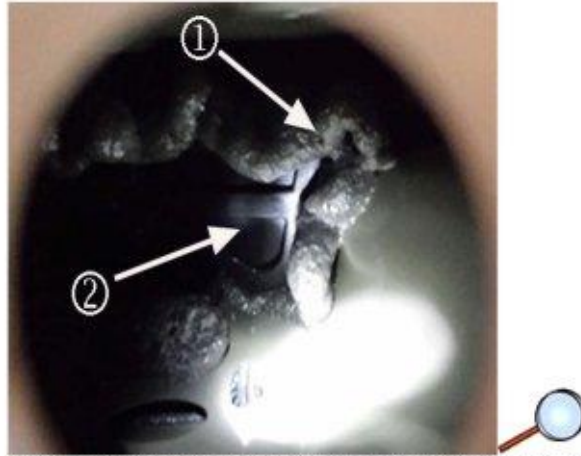

4. Shining a flashlight in the vertical hole, look upward from the bottom hole and inspect the inner rocker for the existence of foam (1) and baffle (2).
5. Repeat steps 3 and 4 on the opposite side rocker panel.
6. Upon inspection of both rocker panels:
  - If there is visual evidence of the foam/baffle in BOTH locations, no further action is required. Reinstall all body plugs and lower the vehicle.
  - If there is NO visual evidence of the foam/baffle in one or either location, reinstall all body plugs, lower the vehicle and continue ahead to the *Expandable Foam Installation Procedure*.

#### Expandable Foam Installation

**Note:** Install expandable foam to the affected side missing the baffle, or to both sides, if both are missing.

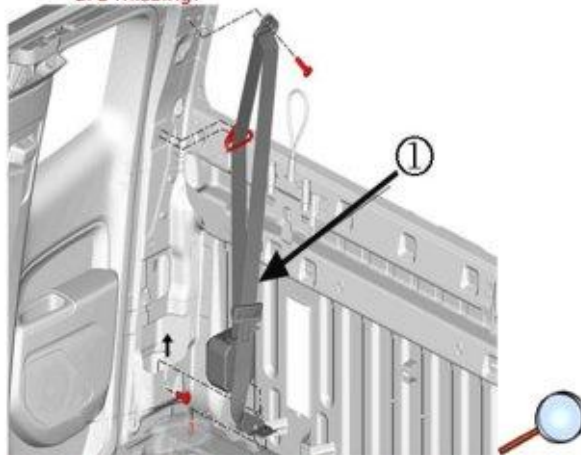

**Note:** If baffles on both sides are missing, remove BOTH rear seat belt retractors as the preliminary steps prior to applying the expandable foam. To avoid the foam curing in the cartridge, the foam application must move immediately from one side to the other.

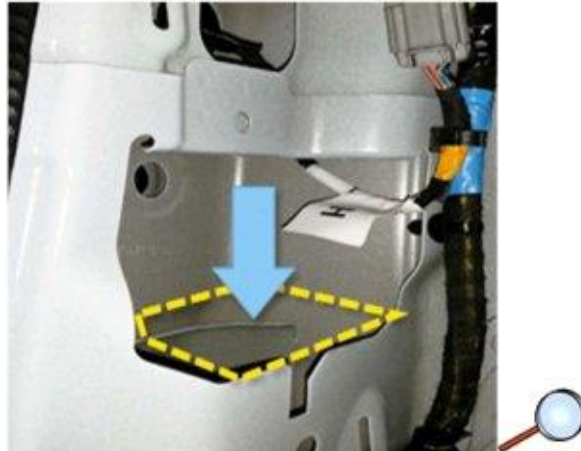

1. Remove the rear seat belt retractor (1), on the affected side(s). Refer to *Rear Seat Belt Retractor Replacement (Extended Cab)* in SI.



2. Access the open pocket in the inner sheet metal.

**Note:** The graphic above shows the top side foam (1) on a **factory installed baffle**. The new single layer of expandable foam should be applied at approximately the same height below the bracket shown.

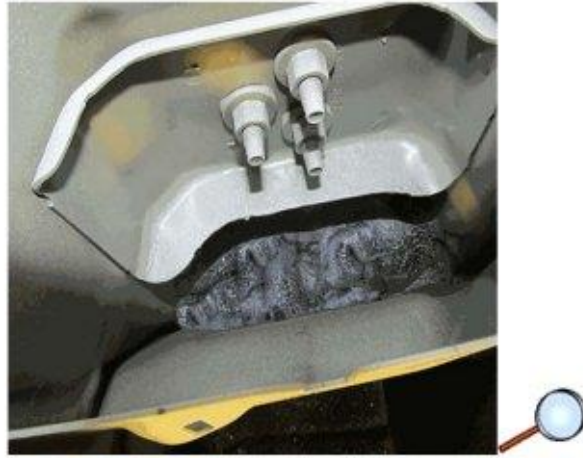

**Note:** If the partially used cartridge is being stored for re-use, the mix tip **MUST BE REMOVED** immediately. If not removed, the foam will cure back into the cartridge and plug it; rendering it useless.

3. Install a layer of *3M™\* Flexible Foam, P/N 08463*, to completely close off the opening. Follow the Tip below to build the foam layer and minimize run down into the cavity.

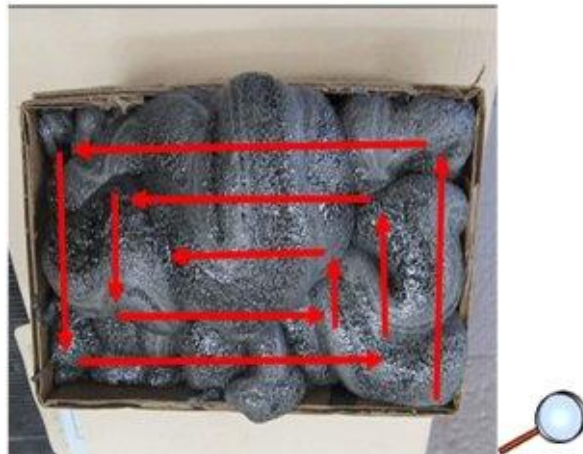

**Tip:** You can control the way this foam applies by "Timing" how it is dispensed. Dispense the foam at a pace which allows the foam to kick off expansion, build upon itself and stay in position better. Starting along one of the outboard sheet metal walls, patiently apply a starting row of foam, then continue building rows inboard until the opening is sealed off. Follow the manufacturer's recommended drying time.

4. If other side baffle is missing, immediately move to the opposite side and apply expandable foam.

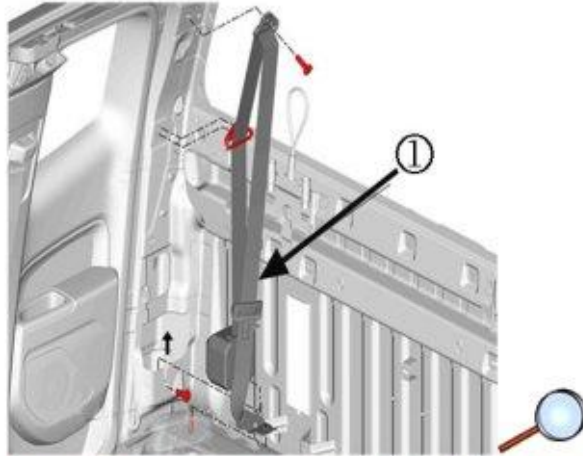

**Note:** The original two bolts retaining each seat belt retractor should be discarded and NOT reused. Replace the bolts with new service bolt P/N 11611776.

5. Reinstall the rear seat belt retractor(s) as necessary. Refer to *Rear Seat Belt Retractor Replacement (Extended Cab)* in SI.

**Warranty Transaction Information**

Submit a transaction using the table below. All transactions should be submitted as a ZFAT transaction type, unless noted otherwise.

Labor Code	Description	Labor Time	Net Item
9101455	Baffle Inspection (Both Sides) – No Further Action Required	0.3	N/A
9101456	Install Expandable Foam (One side) – Includes Inspection Add: Install Expandable Foam (Both Sides) – Includes Inspection	1.8 0.4	*

\* The amount identified in "Net Item" should represent the actual sum total of the cost for the 3M™ flexible foam needed to perform the required repairs, not to exceed \$53.36 USD.

**Dealer Program Responsibility**

Whenever a vehicle subject to this service update enters your vehicle inventory, or is in your facility for service in the future, and the vehicle is still covered under the New Vehicle Limited Warranty, you must take the steps necessary to be sure the service update correction has been made before selling or releasing the vehicle.

GM bulletins are intended for use by professional technicians, NOT a "do-it-yourselfer". They are written to inform these technicians of conditions that may occur on some vehicles, or to provide information that could assist in the proper service of a vehicle. Properly trained technicians have the equipment, tools, safety instructions, and know-how to do a job properly and safely. If a condition is described, DO NOT assume that the bulletin applies to your vehicle, or that your vehicle will have that condition. See your GM dealer for information on whether your vehicle may benefit from the information.



WE SUPPORT  
VOLUNTARY  
TECHNICIAN  
CERTIFICATION